

MM-400 C

Systems for measuring of aggregate moisture with capacitive sensors

INTRODUCTION TO THE SYSTEM

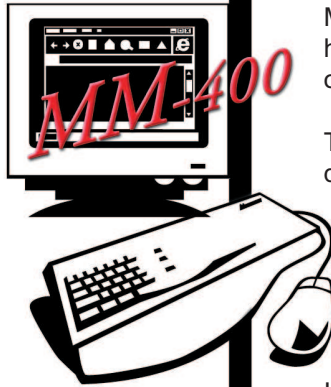

The measuring system of the MM400 is based on an advanced MICROPROCESSOR technology that detects the percentage of moisture held by the aggregates, through specific sensors installed in the weigher or in the storage hoppers.

The instrument can analyze the humidity in 4 AGGREGATES with different diameters: small, medium or large ones. Through a special configuration menu, it allows selection of the most suitable diameter-curve from among the most common ones used in the concrete industry, for easy and straightforward setup.

MM400 has an LCD for a real-time readout of the percentage of moisture detected by the probes connected to it.

It can be used either during a MANUAL production cycle, by selecting the probe through the special keys located on the front panel, or during the AUTOMATIC cycle through special opto-isolated digital inputs that enable the reading of the specific probe only during analysis, instantly transmitting to the automatic batching system the same percentage indicated by the display through the 0-10V analog output or RS232 serial output.



Instrument MM400C

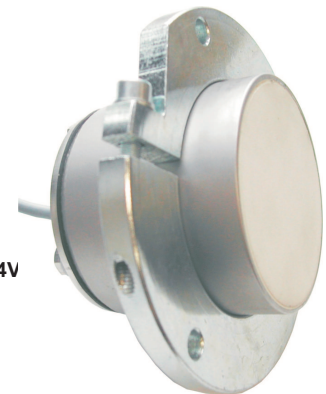

Capacitive sensor CP1R-24V

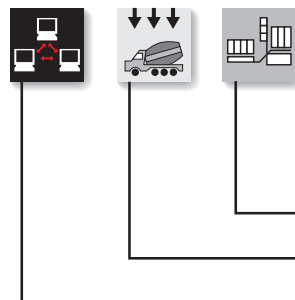

DIRECT SERVICING

Assistenza

Quality

QUALITY ASSURANCE SYSTEM

FOR CERAMIC, AGGREGATES, FOOD INDUSTRY, ETC.

CONCRETE BATCHING PLANTS

INTERFACE WITH AUTOMATION SYSTEMS

MM400C instrument CHARACTERISTICS

- Measurement accuracy: ± 0.3 percent
- Displayable reading field: from 0% to 20%, resolution 0.1%
- Reading settlement: 0.5 seconds
- Maximum probe distance: about 100 meters
- Connection cable: min. 4 x 0.5 mm, shielded
- Display: liquid crystals, 2 x 16 alphanumeric characters
- Keyboard: 6 keys for data input and probe selection
- Container: DIN 72 x 144
- Temperature probe input: PT100
- Analog output for percentage humidity: 0-10 Vdc
- Analog temperature output: 0-10 Vdc
- Power supply: 24 Vac $\pm 10\%$ 50/60 Hz
- Maximum absorption: approx. 25 VA
- Operating temperature: from 0° to 50° C
- Protection: front IP50, back IP20
- Weight: approx. 1 Kg
- Connections: coupling terminals

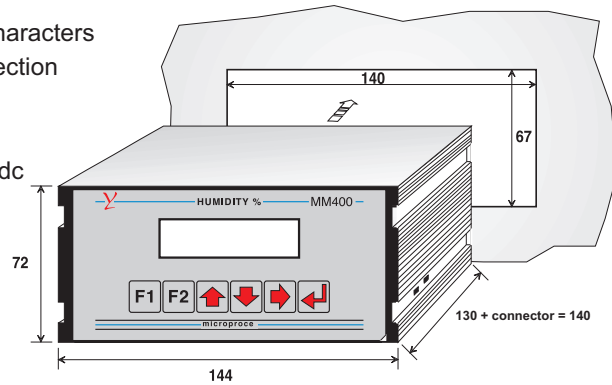

Sensor CP1R-24VDC CHARACTERISTICS

- Moisture detectability range: da 0% a 20%
- Analog out. for percentage humidity: 0-10 Vdc
- Power supply: 24 Vdc $\pm 0.5V$
- Operating temperature: from 0° to 50° C
- Weight: approx. 1 Kg

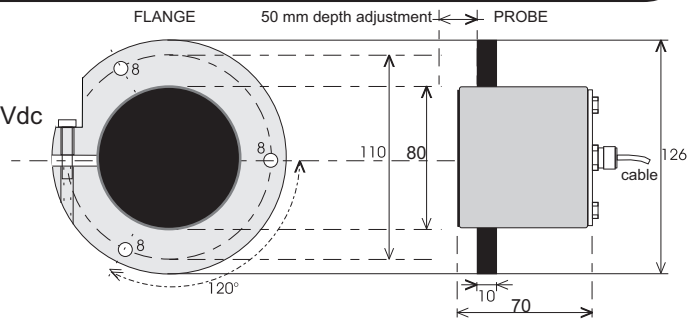

INSTALLATION AND CONNECTION

